



SANCO VALVES

Pvt. Ltd.



we strongly believe in service to our clients
through our products

STANDARD PRODUCT RANGE	04
GATE VALVE	07
GLOBE VALVE	08
SWING CHECK VALVE	09
BALL VALVE	10
FORGED STEEL GATE / GLOBE VALVE	12
WELDED BONNET FORGED STEEL VALVES	13
FORGED STEEL LIFT CHECK VALVE	14
WELDED ON FLANGE FORGED STEEL VALVE	14
WELDED ON FLANGE FORGED GATE / GLOBE VALVE	15
DUAL PLATE WAFER TYPE	16
BUTTERFLY VALVE	16
FLUSH BOTTOM VALVE	17
BASKET STRAINER	18
STEEL FLANGE	19
VALVES SHELL MATERIALS	21
TRIM MATERIAL	21
PRESSURE TEMPERATURE RATINGS	22
VALVES SHELL MATERIALS	24
GENERAL DESIGN SPECIFICATION	25

INDEX



SANCO VALVES
Pvt. Ltd.

SANCO is a leading manufacturers and supplier of the industrial valves company located in Mumbai India. We have been in this filed around 7 years as a regular supplier of the industrial valves to the various fields.

At SANCO we take great pride in meeting your Industrial Valve requirements, promptly and efficiently. Which is why we make sure that all valves are to meet your requirement, at all times, throughout the year.

VALVE TYPE	ANSI CLASS	DESIGN STANDARD	FIG	SIZE
GATE	150	API 60/ BS 1414	1015, 1015WF	2" NB TO 24" NB
	300		1030, 1030WF	2" NB TO 24" NB
	600		1060, 1060WF	2" NB TO 24" NB
GLOBE	150	BS 1873	2015, 2015WF	2" NB TO 24" NB
	300		2030, 2030WF	2" NB TO 20" NB
	600		2060, 2060WF	2" NB TO 12" NB
LIFT CHECK	150	BS 5352	3015WF	
	300		3030WF	0.5" TO 1.5"NB
	600		3060WF	
SWING CHECK	150	BS 1868	4015	2" NB TO 24" NB
	300		4030	2" NB TO 20" NB
	600		4060	2" NB TO 16" NB
BALL	150	BS 5351/ API 6D	50151R, 5015F, 50153F	1.5" NB TO 24" NB
	300		50301R, 50302F, 50303F	1.5" NB TO 16" NB
	600		50602F, 50603F	1.5" NB TO 8" NB
	800		5080	1/2" NB TO 2" NB
FORGED STEEL GATE	800	API 602/ BS 5352/ ASME B16.34	F1080	1/4" NB TO 2" NB
	1500		F1150	1/4" NB TO 1 1/2" NB
	2500		F1250	1/4" NB TO 1 1/2" NB
FORGED STEEL GLOBE	800	BS 5352/ ASME B16.34	F2080	1/4" NB TO 1 1/2" NB
	1500		F2150	1/4" NB TO 1 1/2" NB
	2500		F2250	1/4" NB TO 1 1/2" NB
FORGED LIFT CHECK	800	BS 5352/ ASME B16.34	F3080	1/4" NB TO 1 1/2" NB
	1500		F3150	1/4" NB TO 1 1/2" NB
	2500		F3250	1/4" NB TO 1 1/2" NB

NOTE : APPLICABLE STANDARDS ARE REFERRED WHERE SIZE RANGE EXCEEDS DESIGN STANDARD

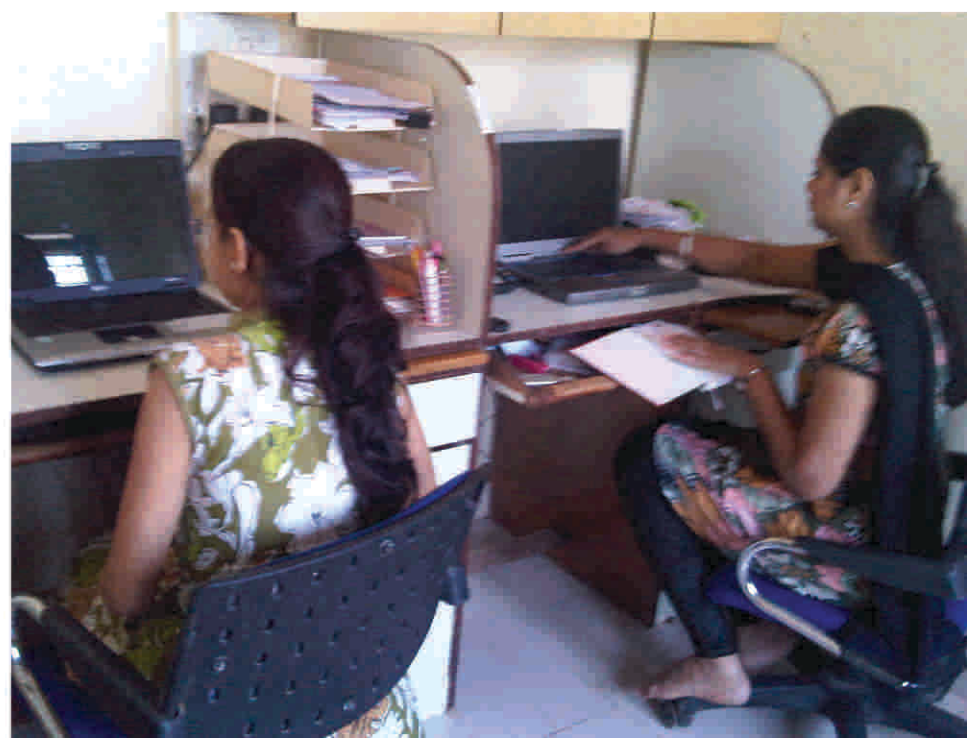

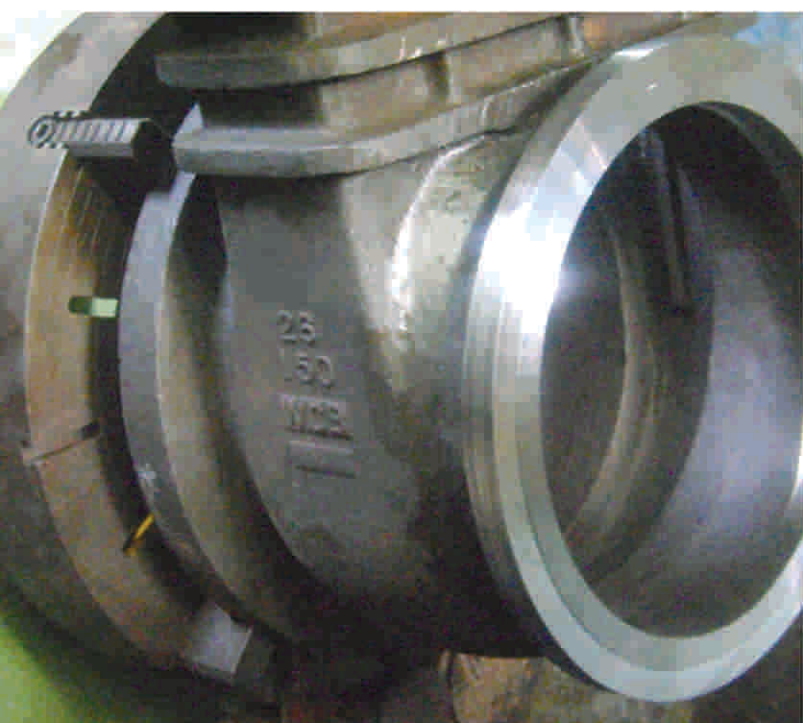

Length ANSI B16.10 - Flange ANSI B16.5

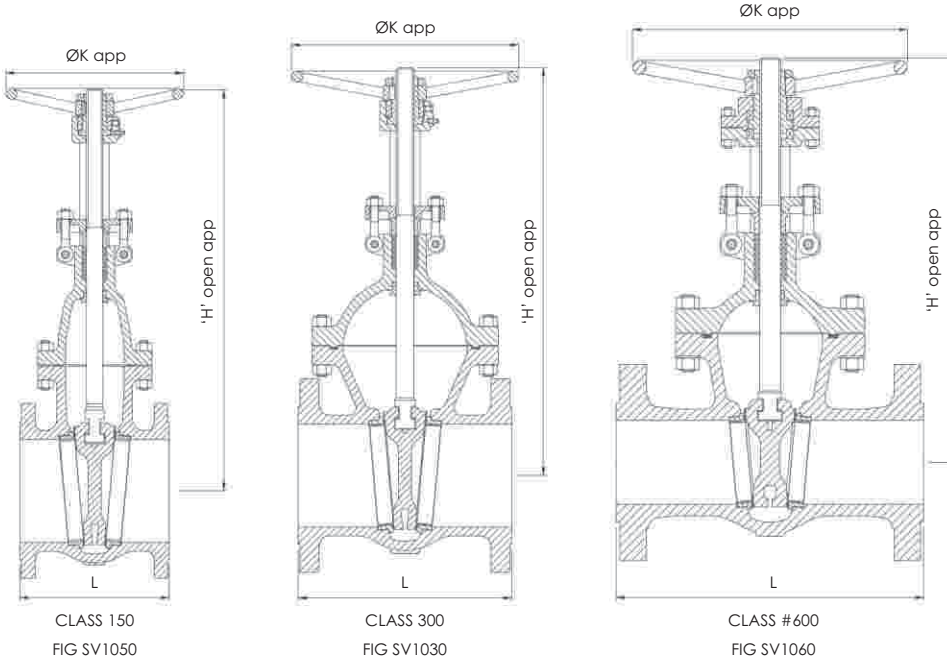

DIMENSION TABLE #150

SIZE	in	2	2.5	3	4	5	6	8	10	12	14	16	18	20	22	24
	mm	50	65	80	100	125	150	200	250	300	350	400	450	500	550	600
L		7.0 178	7.5 190	8.0 203	9.0 229	10.0 254	10.5 267	11.5 292	13.0 330	14.0 356	15.0 381	16.0 406	17.0 432	19.0 483	19.0 483	20.0 508
L1		8.5 216	9.5 241	11.12 282.5	12.0 305	15.0 381	15.9 403	16.5 419	18.0 457	19.8 502	22.5 572	24.0 610	26.0 660	30.0 762	30.0 762	32.0 813
H app		400	445	485	600	725	765	985	1220	1395	1500	1775	2000	2530	2530	2725
ØK app		200	200	250	250	300	300	350	450	500	559	559	610	660	660	660
Wt. kg app		20	28	33	55	70	90	130	225	330	450	530	625	1150	1150	1210

DIMENSION TABLE #300

SIZE	in	2	2.5	3	4	5	6	8	10	12	14	16	18	20	22	24
	mm	50	65	80	100	125	150	200	250	300	350	400	450	500	550	600
L		8.5 216	9.5 241	11.12 282.5	12.0 305	15.0 381	15.88 403	16.5 419	18.0 457	19.8 502	30.0 762	33.0 838	36.0 914	39.0 991	43.0 1092	45.0 1143
L1		8.5 216	9.5 241	11.12 282.5	12.0 305	15.0 381	15.88 403	16.5 419	18.0 457	19.8 502	30.0 762	33.0 838	36.0 914	39.0 991	43.0 1092	45.0 1143
H app		410	450	485	615	725	835	1015	1230	1555	1720	1970	2160	2410	2550	2810
ØK app		200	250	250	300	350	350	450	500	600	600	680	760	760	760	
Wt. kg app		32	35	55	80	100	150	225	350	480	745	1060	1325	1725	1900	2570

DIMENSION TABLE #600

SIZE	in	2	2.5	3	4	5	6	8	10	12	14	16	18	20	22	24
	mm	50	65	80	100	125	150	200	250	300	350	400	450	500	550	600
L		11.5 292	13.0 330	14.0 356	17.0 432	20.0 508	22.0 559	26.0 660	31.0 787	33.0 838	35.0 889	39.0 991	43.0 1092	47.0 1194	51.0 1295	55.0 1397
L1		11.5 292	13.0 330	14.0 356	17.0 432	20.0 508	22.0 559	26.0 660	31.0 787	33.0 838	35.0 889	39.0 991	43.0 1092	47.0 1194	51.0 1295	55.0 1397
H app		410	485	560	705	800	895	1125	1400	1535	1825	1955	2140	2310	2680	2680
ØK app		250	250	350	450	500	500	600	680	760	760	760	760	813	889	500
Wt. kg app		38	56	72	136	170	245	432	780	835	1190	1690	2010	2400	2650	3700

PARTS	MATERIAL SPECIFICATION		
BODY	WCB	WC6	CF8/ CF8M
BONNET	WCB	WC6	CF8/ CF8M
YOKE	WCB	WC6	CF8/ CF8M
WEDGE	13 CR. FACING ON WCB	13 CR. FACING ON WC6	CF8/ CF8M
SEAT RING	13 CR. FACING ON A515-70	S.S. 304	T304 / T316 CF8/ CF8M
BACK SEAT	T410		INTEGRAL
SPINDLE	T410		T304/ T316
GLAND BUSH	T410		T304/ T316
GLAND FLANGE	CARBON STEEL/WCB		S.S 304
YOKE SLEEVE	ASTM A 439 Gr.D2/ AL-BRONZE		
YOKE NUT	ASTM A 515-70		S.S 304
HAND WHEEL	CARBON STEEL		
HAND WHEEL NUT	CARBON STEEL		S.S 304
STUD & NUT	B7/2H	B16/7	B7/2H
EYE BOLT & NUT	B7/ 2H		B8/ 8
CROSS BOLT & NUT	B7/ 2H		B8/ 8
GASKET	CORR. SOFT IRON	CORR. S.S 304	CORR. S.S304/316
GLAND PACKING	GRAPHITE ASB. INHIB. & INCONEL WIRE REIN./GRAPHOIL		
GRUB SCREW	STEEL		
GREASE NIPPLE	BRASS/ STEEL		
NAME PLATE	ALUMINIUM/SS		

Length ANSI B16.10 - Flange ANSI B16.5

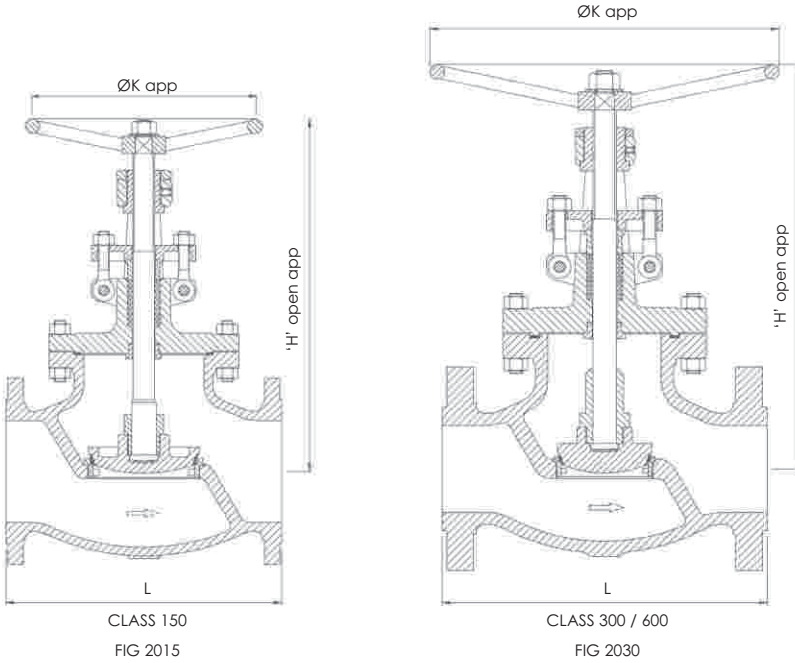

DIMENSION TABLE #150

SIZE	in	2	2.5	3	4	5	6	8	10	12	14	16	18	20	22	24
	mm	50	65	80	100	125	150	200	250	300	350	400	450	500	550	600
L		8.0 203	8.5 216	9.5 241	11.5 292	14.0 356	16.0 406	19.5 495	24.5 622	27.5 698	31.0 787	36.0 914	38.5 978	38.5 978	42.0 1067	51.0 1295
L1		8.0 203	8.5 216	9.5 241	11.5 292	14.0 356	16.0 406	19.5 495	24.5 622	27.5 698	31.0 787	36.0 914	38.5 978	38.5 978	42.0 1067	51.0 1295
H app		320	330	380	480	525	575	650	780	935	1185	1250	1350	1410	1525	1650
ØK app		200	200	250	300	300	350	450	500	600	700	750	800	800	850	900
Wt. kg app		20	30	38	57	75	98	155	225	360	580	800	910	1100	1300	1450

DIMENSION TABLE #300

SIZE	in	2	2.5	3	4	5	6	8	10	12	14	16	18	20
	mm	50	65	80	100	125	150	200	250	300	350	400	450	500
L		10.5 267	11.5 292	12.5 318	14.0 356	15.7 400	17.5 444	22.0 559	24.5 622	28.0 711	33.0 838	34.0 864	38.5 978	40.0 1016
L1		10.5 267	11.5 292	12.5 318	14.0 356	15.7 400	17.5 444	22.0 559	24.5 622	28.0 711	33.0 838	34.0 864	38.5 978	40.0 1016
H app		360	410	450	530	590	650	735	825	950	1145	1370	1422	1475
ØK app		200	250	300	350	400	450	600	700	750	800	800	850	900
Wt. kg app		30	45	60	95	125	150	235	390	590	965	1115	1400	1800

DIMENSION TABLE #600

SIZE	in	2	2.5	3	4	5	6	8	10	12
	mm	50	65	80	100	125	150	200	250	300
L		11.5 292	13.0 330	14.0 356	17.0 432	20.0 508	22.0 559	26.0 660	31.0 787	33.0 838
L1		11.5 292	13.0 330	14.0 356	17.0 432	20.0 508	22.0 559	26.0 660	31.0 787	33.0 838
H app		400	425	490	635	685	740	975	1080	1230
ØK app		250	300	350	400	450	500	600	650	700
Wt. kg app		35	40	68	128	185	250	435	825	910

PARTS	MATERIAL SPECIFICATION		
BODY	WCB	WC6	CF8/ CF8M
BONNET	WCB	WC6	CF8/ CF8M
PLUG	CA15/13 CR. FACING ON WCB	WC6+ 13 CR. FACING	CF8/ CF8M
SEAT RING	CA15/A515-70/ 13 CR. FACING	S.S. 304	CF8/ CF8M
BACK SEAT	T410		INTEGRAL
SPINDLE	T410		T304/ T316
GLAND BUSH	T410		T304/ T316
GLAND FLANGE	CARBON STEEL/WCB		S.S 304
YOKE NUT	ASTM A 439 GR.D2/ AL-BRONZE		
PLUG NUT	T410		T304
HAND WHEEL	CARBON STEEL		
HAND WHEEL NUT	GR.2H	S.S 304	
STUD & NUT	B7/2H	B16/7	B7/2H
EYE BOLT & NUT	B7/ 2H		B8/ 8
CROSS BOLT & NUT	B7/ 2H		B8/ 8
GASKET	SPW S.S 304/ 316 WITH CAF		
GLAND PACKING	GRAPHITE ASB. INHIB. & INCONEL WIRE REIN./GRAPHOIL		
THRUST WASHER	T410 (HARDENED STEEL)		T304/ T316
WASHER	STEEL		
GRUB SCREW	STEEL		
LOCK NUT	STEEL		
NAME PLATE	ALUMINIUM/SS		

SWING CHECK VALVE

Class 150 - 300 - 600
BS1868



Length ANSI B16.10 - Flange ANSI B16.5

DIMENSION TABLE #150

SIZE	in	2	2.5	3	4	5	6	8	10	12	14	16	18	20	22	24
	mm	50	65	80	100	125	150	200	250	300	350	400	450	500	550	600
L		8.0 203	8.5 216	9.5 241	11.5 292	13.0 330	14.0 356	19.5 495	24.5 622	27.5 698	31.0 787	34.0 864	38.5 978	38.5 978	42.0 1067	51.0 1295
L1		8.0 203	8.5 216	9.5 241	11.5 292	13.0 330	14.0 356	19.5 495	24.5 622	27.5 698	31.0 787	34.0 864	38.5 978	38.5 978	42.0 1067	51.0 1295
H app		145	165	170	205	225	255	300	340	485	465	595	545	600	695	750
Wt. kg app		18	25	32	52	56	92	136	220	345	485	570	770	1055	1255	1325

DIMENSION TABLE #300

SIZE	in	2	2.5	3	4	5	6	8	10	12	14	16	18	20
	mm	50	65	80	100	125	150	200	250	300	350	400	450	500
L		10.5 267	11.5 292	12.5 318	14.0 356	15.7 400	17.5 444	21.0 533	24.5 622	28.0 711	33.0 838	34.0 864	38.5 978	40.0 1016
L1		10.5 267	11.5 292	12.5 318	14.0 356	15.7 400	17.5 444	21.0 533	24.5 622	28.0 711	33.0 838	34.0 864	38.5 978	40.0 1016
H app		155	215	185	220	245	275	300	375	430	520	560	686	610
Wt. kg app		25	40	60	80	105	130	215	345	470	685	998	1050	1220

DIMENSION TABLE #600

SIZE	in	2	2.5	3	4	5	6	8	10	12	14	16
	mm	50	65	80	100	125	150	200	250	300	350	400
L		11.5 292	13.0 330	14.0 356	17.0 432	20.0 508	22.0 559	26.0 660	31.0 787	33.0 838	35.0 889	39.0 991
L1		11.5 292	13.0 330	14.0 356	17.0 432	20.0 508	22.0 559	26.0 660	31.0 787	33.0 838	35.0 889	39.0 991
H app		160	260	230	280	290	330	360	475	555	580	665
Wt. kg app		29	55	65	115	145	250	405	620	815	970	1215

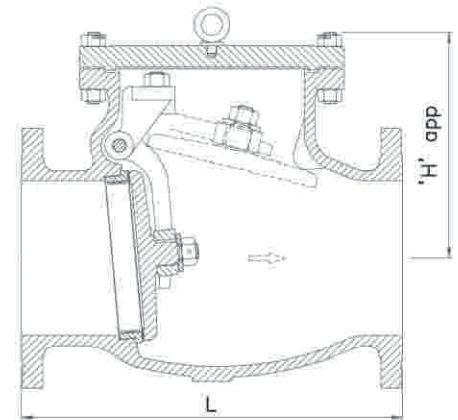

CLASS 150
FIG SV4015

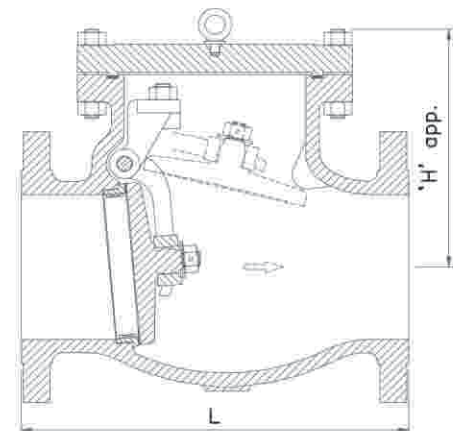

CLASS 300
FIG SV4030

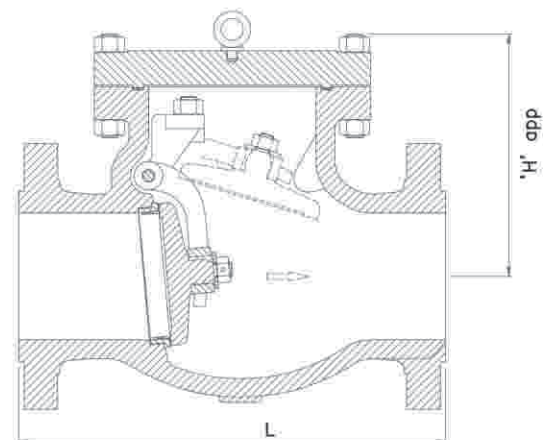

CLASS 600
FIG SV4060



PARTS	MATERIAL SPECIFICATION		
BODY	WCB	WC6	CF8/ CF8M
DISC	CA15/ 13 Cr. FACING ON WCB	WC6+13 Cr	CF8/ CF8M
SEAT RING	CA15/A515GR70+ 13CCR. FACING	SS 304	T304/ T316
TOP COVER	WCB/GR 70	WC6	CF8/ CF8M
STUD & NUT	B7/ 2H	B16/7	B7/2H
BRACKET STUD & NUT		B8/ 8	
GASKET	SPW S.S 304/316 WITH CAF		
WASHER	T410	T304	T316
DISC NUT		GR 8	
HINGE PIN	T410	T304	T316
SPLIT PIN	T410	T304	T316
NAME PLATE	ALUMINIUM/SS		
HINGE	WCB/GR. 70	WC6/CF8	CF8/ CF8M
HINGE BRACKET	WCB/GR. 70	WC6/CF8	CF8/ CF8M
LIFTING EYE BOLT	ASTM A 105		

Length 150/300 ANSI B16.10 - Flange ANSI B16.5



DIMENSION TABLE #150
FLOATING BALL VALVE 1-PIECE REDUCE BORE

SIZE	in	1	1.5	2	2.5	3	4	6
	mm	25	40	50	65	80	100	150
L		5.0 127	6.5 165	7.0 178	7.5 190	8.0 203	9.0 229	10.5 267
H app		95	100	125	140	175	195	235
K app		220	220	220	320	320	385	500
ØP		17	28	36	50	57	75	98
Wt. kg app		3	6	8.5	17	21	30	42

DIMENSION TABLE #300
FLOATING BALL VALVE 1-PIECE REDUCE BORE

SIZE	in	1	1.5	2	2.5	3	4	6
	mm	25	40	50	65	80	100	150
L		5.0 127	6.5 165	7.0 178	7.5 190	8.0 203	9.0 229	10.5 267
H app		95	100	125	140	175	195	235
K app		220	220	220	320	320	385	500
ØP		17	28	36	50	57	75	98
Wt. kg app		3	6	8.5	17	21	30	42

DIMENSION TABLE #800
BALL VALVE WITH NIPPLE

SIZE	in	0.5	0.75	1	1.25	1.5	2
	mm	15	20	25	32	40	50
L		10.8 275	11.0 280	11.8 300	12.4 315	12.6 320	13.8 350
H app		70	80	90	105	110	125
K app		130	140	160	240	240	240
ØP		12	19	24	30	37	50
Wt. kg app		1.4	2	3.5	6	7	8

DIMENSION TABLE #800
SOCKET / SCREWED END

SIZE	in	0.5	0.75	1	1.25	1.5	2
	mm	15	20	25	32	40	50
L		3.1 80	3.3 85	3.9 100	4.5 115	5.1 130	5.9 150
H app		70	80	90	105	110	125
K app		130	140	160	240	240	240
ØP		12	19	24	30	37	50
Wt. kg app		1.4	2	3.5	6	7	8

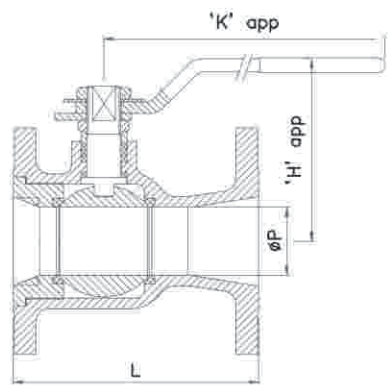

CLASS 150
FIG SV50151R

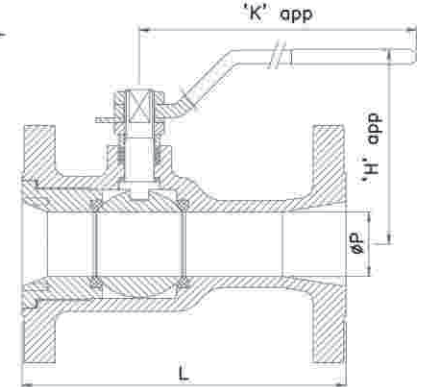

CLASS 300
FIG SV50301R

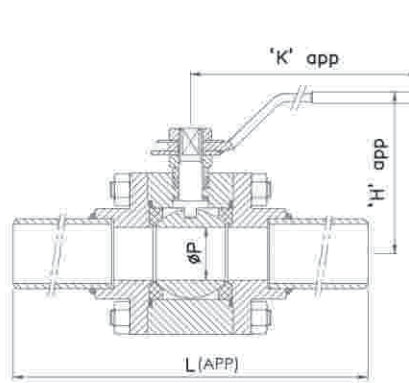

CLASS 800 WITH NIPPLE
FIG 5080E

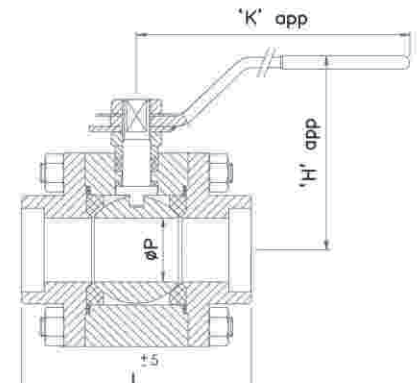

CLASS 800
FIG 5080SW

PARTS	MATERIAL SPECIFICATION		
BODY	WCB/A105	CF8	CF8M
BALL	T304/CF8/CF8M		T316/CF8M
SEAT	PTFE		
SPINDLE	T410/ T304/316	T304	T316
GLAND BUSH	T410/ T304/316	T304	T316
HANDLE	STEEL WITH PVC CAP		
HANDLE NUT	STEEL	T304	
STUD & NUT	B7/ 2H		
GASKET	PTFE		
GLAND PACKING	PTFE		
BOTTOM WASHER	PTFE		
END PIECE	WCB	CF8	CF8M
GLAND NUT	CARBON STEEL	T304	T316
NAME PLATE	ALUMINIUM/SS		
POSITION INDICATOR	ALUMINIUM/SS		

Length ANSI B16.10 - Flange ANSI B16.5

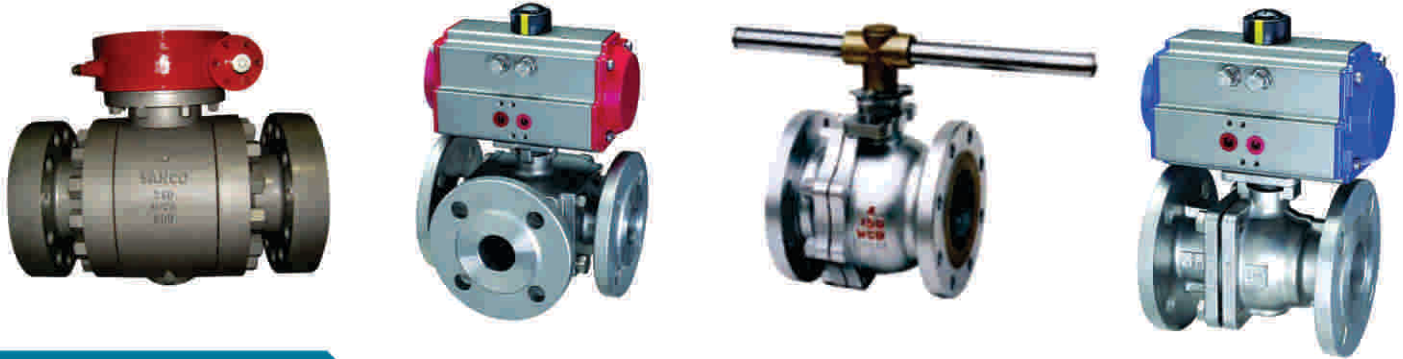

DIMENSION TABLE # 150
FLOATING BALL VALVE 2-3 PIECE FULL BORE

SIZE	in	1.5	2	2.5	3	4	6	8	10	12
	mm	40	50	65	80	100	150	200	250	300
L		6.5 165	7.0 178	7.5 191	8.0 203	9.0 229	15.5 394	18.0 457	21.0 533	24.0 610
H app		100	125	140	150	180	270	325	390	540
K app		220	220	320	320	385	500	600	450	450
ØP		37	49	64	75	98	148	198	248	298
Wt. kg app		9	14	20	27	40	90	165	225	325

DIMENSION TABLE #300
FLOATING BALL VALVE 2-3 PIECE FULL BORE

SIZE	in	1.5	2	2.5	3	4	6	8
	mm	40	50	65	80	100	150	200
L		7.5 190	8.5 216	9.5 241	11.1 282	12.0 305	15.9 403	19.75 502
H app		120	135	150	170	190	300	360
K app		220	220	320	320	385	500	450
ØP		37	49	64	75	98	148	198
Wt. kg app		12	18	28	35	55	110	235

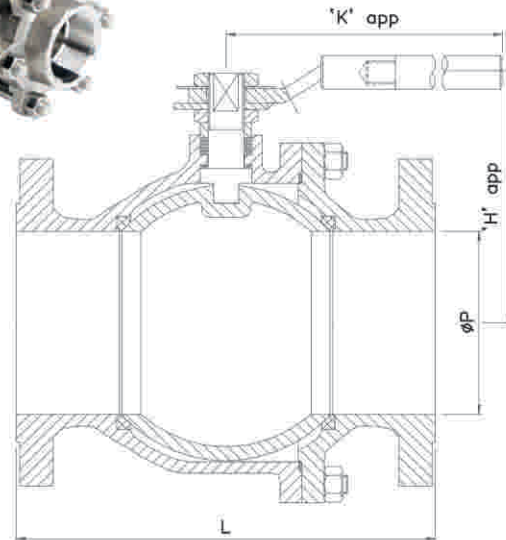

CLASS 150/300 2PIECE
FIG SV50152F

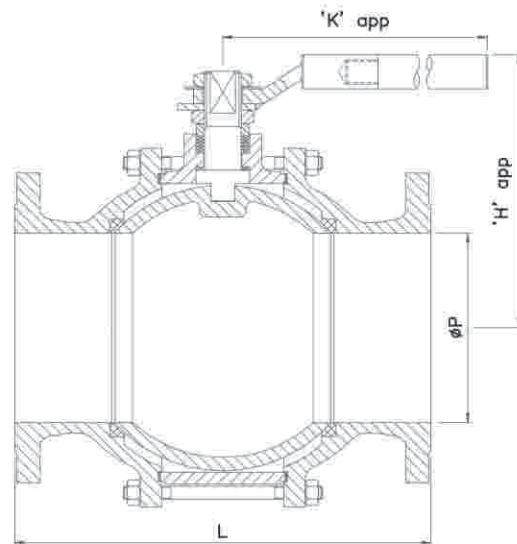

CLASS 150/300 3PIECE
FIG SV50153F

PARTS	MATERIAL SPECIFICATION		
BODY	WCB	CF8	CF8M
BALL	T304/CF8/CF8M		T316/CF8M
SEAT	PTFE		
SPINDLE	T410/ T304/316	T304	T316
GLAND BUSH	T410/ T304	T304	T316
HANDLE	STEEL		
HANDLE NUT	STEEL	T304	
STUD & NUT	B7/ 2H		
GASKET	PTFE		
GLAND PACKING	PTFE		
BOTTOM WASHER	PTFE		
END PIECE	WCB	CF8	CF8M
GLAND NUT	CARBON STEEL	T304	T316
NAME PLATE	ALUMINIUM/SS		
POSITION INDICATOR	ALUMINIUM/SS		



DIMENSION TABLE
GATE VALVE REDUCE BORE

SIZE	in	0.25	0.37	0.5	0.75	1	1.5	2
	mm	08	10	15	20	25	40	50
L		3.3 85	3.3 85	3.3 85	3.5 90	4 103	5 128	5.6 142
H app		165	165	165	175	215	270	285
ØK app		95	95	95	95	105	150	150
ØP		6.4	6.4	9.5	12.7	17.5	28.6	36.5
Wt. kg app		2.0	2.0	2.0	2.5	3.5	7.5	9.0

DIMENSION TABLE
GATE VALVE FULL BORE

SIZE	in	0.25	0.37	0.5	0.75	1	1.5
	mm	08	10	15	20	25	40
L		3.3 85	3.3 85	3.5 90	3.5 90	4 103	5 128
H app		165	165	175	175	220	270
ØK app		95	95	95	95	105	150
ØP		6.0	9.0	12.0	18.0	23.0	36.0
Wt. kg app		2.0	2.0	2.5	3.5	7.5	7.5

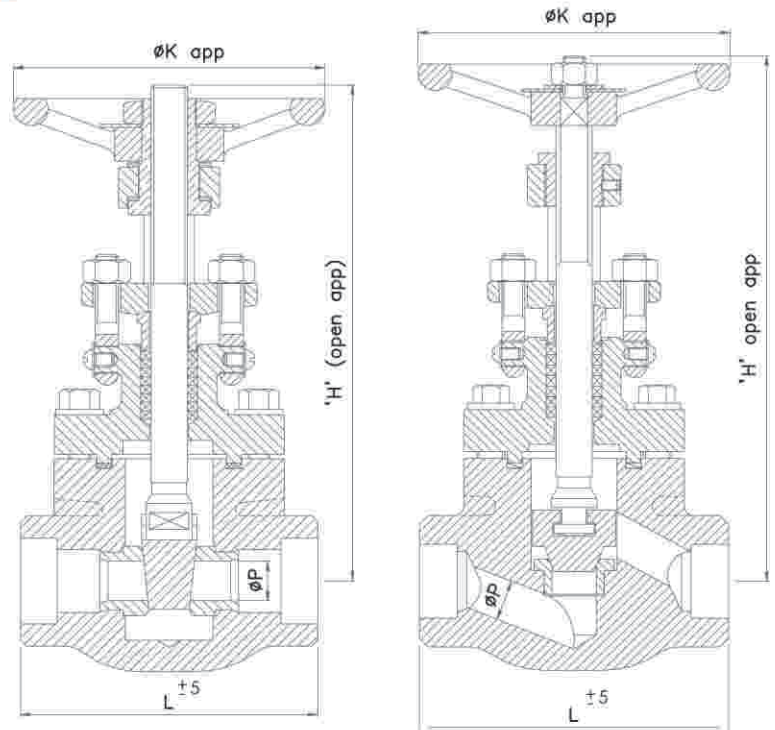

CLASS 800
FIG SV F1080

CLASS 800
FIG SV F2080

DIMENSION TABLE
GLOBE VALVE REDUCE BORE

SIZE	in	0.25	0.37	0.5	0.75	1	1.5	2
	mm	08	10	15	20	25	40	50
L		3.3 85	3.3 85	3.3 85	3.5 90	4 103	5 128	5.6 142
H app		170	170	170	185	210	280	290
ØK app		95	95	95	95	105	150	150
ØP		6.0	6.0	9.0	12.0	17.5	29.5	35.0
Wt. kg app		2.0	2.0	2.0	2.5	4.0	8.5	9.0

DIMENSION TABLE
GLOBE VALVE REDUCE BORE

SIZE	in	0.25	0.37	0.5	0.75	1	1.5
	mm	08	10	15	20	25	40
L		3.3 85	3.3 85	3.5 90	4 103	5 128	5 128
H app		170	170	170	210	280	280
ØK app		95	95	95	105	150	150
ØP		6.0	9.0	12.0	17.5	29.5	35.0
Wt. kg app		2.0	2.0	2.5	4.0	8.5	9.0

PARTS	MATERIAL SPECIFICATION		
BODY	A105	F304	F316
BONNET	A105	F304	F316
WEDGE/PLUG	13CR.	T304	T316
SEAT	13CR.	T304	T316
SPINDLE	T410	T304	T316
GLAND BUSH	T410	T304	T316
GLAND FLANGE	A105	F304	
YOKE SLEEVE YOKE NUT	ASTM A 439 GR.D2/ AL-BRONZE		
HAND WHEEL	CAST STEEL		
HAND WHEEL NUT	GR.2H		
COLLAR BOLT/ STUD & NUT	B7/ 2H	B8/ 8 OR B7/ 2H	
EYE BOLT & NUT	B7/ 2H	B8/ 8	
GASKET	SPW S.S 304/316 WITH CAF/ GRAFOIL		
GLAND PACKING	GRAPHITE ASBESTOS INHIB. & INCONEL WIRE REIN.		
SCREW/RIVET&WASHER	STEEL		
BEARING WASHER	HARDENED STEEL	T304	T316
GRUB SCREW	GR.B7		
GREASE NIPPLE	C.S (NICKLE PLATED)		
NAME PLATE	ALUMINIUM/SS		

WELDED BONNET FORGED STEEL VALVES

Class 1500 - 2500
BS5352 / API 602
ASME B16.34

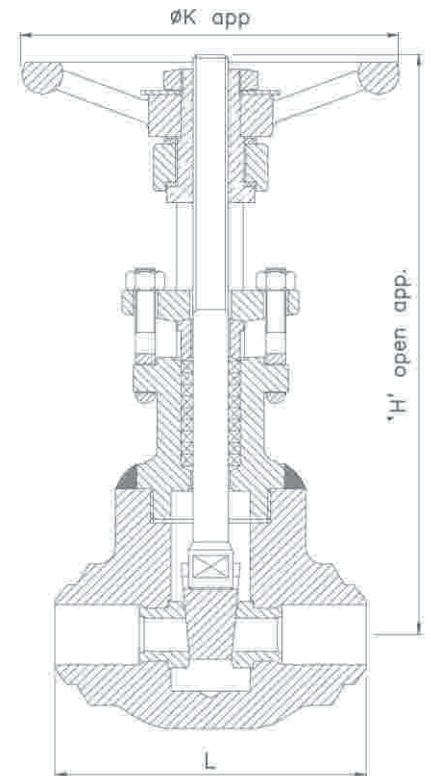

GATE VALVE
FIG SVF1150 - SVF1250

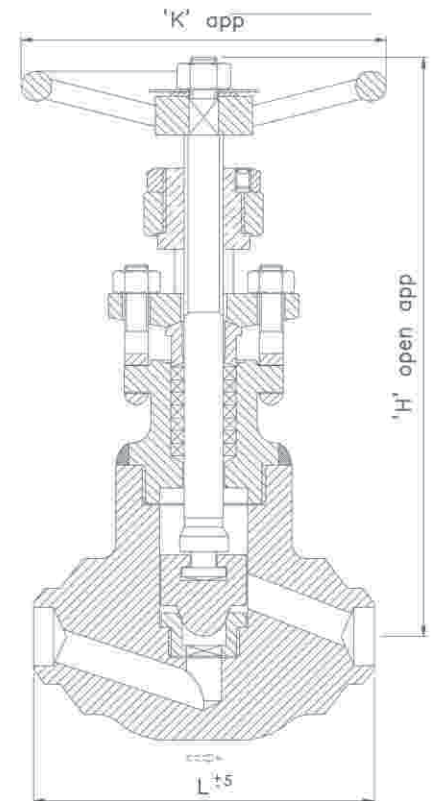

GLOBE VALVE
FIG SVF2150 - SVF2250

DIMENSION TABLE #1500 GATE VALVE

SIZE	in	0.25	0.37	0.5	0.75	1	1.5
	mm	08	10	15	20	25	40
L		90	90	103	103	128	142
H app		160	160	205	205	260	275
ØP		105	105	140	140	150	150
Wt. kg app		2.6	2.6	3.6	3.6	7.6	10

DIMENSION TABLE #1500 GLOBE VALVE

SIZE	in	0.25	0.37	0.5	0.75	1	1.5
	mm	08	10	15	20	25	40
L		90	90	103	103	128	142
H app		160	160	205	205	270	280
ØP		105	105	140	140	150	150
Wt. kg app		2.6	2.6	3.6	3.6	7.6	10

DIMENSION TABLE #2500 GATE VALVE

SIZE	in	0.25	0.37	0.5	0.75	1	1.5
	mm	08	10	15	20	25	40
L		90	90	103	128	128	142
H app		160	160	205	260	260	275
ØP		105	105	140	150	150	150
Wt. kg app		2.6	2.6	3.6	7.6	7.6	10

DIMENSION TABLE #2500 GLOBE VALVE

SIZE	in	0.25	0.37	0.5	0.75	1	1.5
	mm	08	10	15	20	25	40
L		90	90	103	128	128	142
H app		160	160	205	270	270	280
ØP		105	105	140	150	150	150
Wt. kg app		2.6	2.6	3.6	7.6	7.6	10

PARTS MATERIAL SPECIFICATION

PARTS	MATERIAL SPECIFICATION		
BODY	A105	F304	F316
BONNET	A105	F304	F316
WEDGE/PLUG	13CR.	T304	T316
SEAT	13CR.	T304	T316
SPINDLE	T410	T304	T316
GLAND BUSH	T410	T304	T316
GLAND FLANGE	A105	F304	
YOKE SLEEVE YOKE NUT	ASTM A 439 GR.D2/ AL-BRONZE		
HAND WHEEL	CAST STEEL		
HAND WHEEL NUT	GR.2H		
EYE BOLT & NUT	B7/ 2H	B8/ 8	
GLAND PACKING	GRAPHITE ASBESTOS INHIB. & INCONEL WIRE REIN.		
SCREW/RIVET&WASHER	STEEL		
BEARING WASHER	HARDENED STEEL	T304	T316
GRUB SCREW	GR.B7		
GREASE NIPPLE	C.S (NICKLE PLATED)		
NAME PLATE	ALUMINIUM/SS		

FORGED STEEL LIFT CHECK VALVE

Class 800
BS5352 / ASME B16.34



**DIMENSION TABLE #800
REDUCE BORE**

SIZE	in mm	0.25 08	0.37 10	0.5 15	0.75 20	1 25	1.5 40	2 50
L		3.3 85	3.3 85	3.3 85	3.5 90	4 103	5 128	5.6 142
H app		60	60	60	70	80	105	115
ØP		-	6.0	9.0	12.0	17.5	29.5	35.0
Wt. kg app		1.5	1.5	1.5	2.0	2.5	6	8

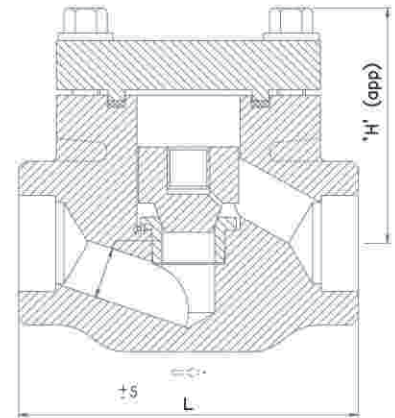

**DIMENSION TABLE #800
FULL BORE**

SIZE	in mm	0.25 08	0.37 10	0.5 15	0.75 20	1 25	1.5 40
L		3.3 85	3.3 85	3.5 90	4 103	5 128	5.6 142
H app		60	60	70	80	105	115
ØP		6.0	9.0	12.0	17.5	22.5	35.0
Wt. kg app		1.5	1.5	2.0	2.5	6	8

PARTS MATERIAL SPECIFICATION

PARTS	MATERIAL SPECIFICATION		
BODY	A105	F304	F316
PLUG	13%CR.	T304	T316
SEAT RING	13%CR.	T304	T316
COVER	A105	F304	F316
YOKE SLEEVE YOKE NUT	B7 / 2H	B8 / 8 OR B7 / 2H	
GASKET	SPW S.S 304/316 WITH CAF/ GRAFOIL		
NAME PLATE	ALUMINIUM/SS		

WELDED ON FLANGE FORGED STEEL VALVE

Class 150 - 300 - 600
BS5352

DIMENSION TABLE #150

SIZE	in mm	0.5 15	0.75 20	1 25	1.5 40
L		4.25 108	4.6 118	5 127	6.5 165
H app		60	70	80	105
Wt. kg app		2	3	3.8	11.5

DIMENSION TABLE #300

SIZE	in mm	0.5 15	0.75 20	1 25	1.5 40
L		6.0 152.5	7.0 178	8.0 203	9.0 228.5
H app		60	70	80	105
Wt. kg app		2.5	3.5	7.5	12

DIMENSION TABLE #600

SIZE	in mm	0.5 15	0.75 20	1 25	1.5 40
L		6.5 165	7.5 190.5	8.5 216	9.5 241
H app		70	80	105	115
Wt. kg app		2.75	3.7	8.5	13.5

PARTS MATERIAL SPECIFICATION

PARTS	MATERIAL SPECIFICATION		
BODY	A105	F304	F316
PLUG	13%CR.	T304	T316
SEAT	13%CR.	T304	T316
COVER	A105	F304	F316
COLLAR BOLT/ STUD & NUT	B7 / 2H	B8 / 8 OR B7 / 2H	
GASKET	SPW S.S 304/316 WITH CAF/ GRAFOIL		
NAME PLATE	ALUMINIUM/SS		

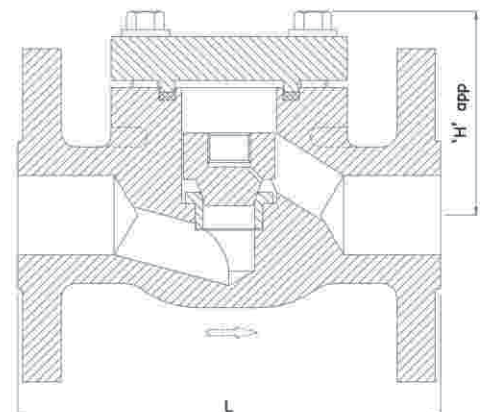

Length ANSI B16.10 - Flange ANSI B16.5

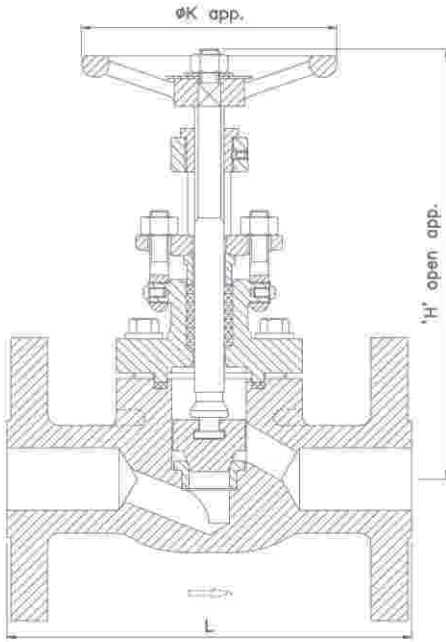

FIG SV2015WF - 2030WF - 2060WF

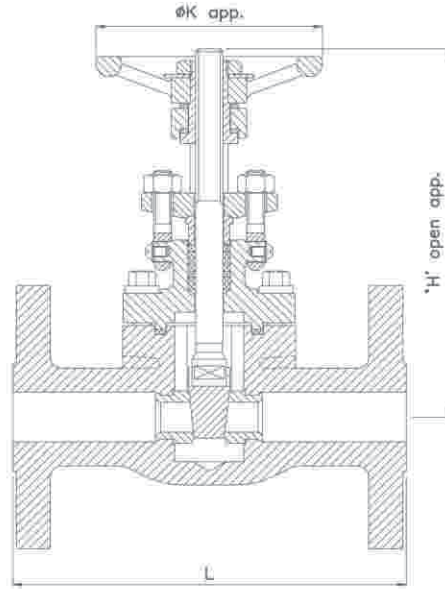

FIG SV1015WF - 1030WF - 1060WF



DIMENSION TABLE #150 GLOBE VALVE					
SIZE	in	0.5	0.75	1	1.5
	mm	15	20	25	40
L		4.25	4.6	5	6.5
		108	117	127	165
H app		170	180	210	280
ØK app		95	95	105	150
Wt. kg app		3.0	4.5	6.0	10.0

DIMENSION TABLE #150 GATE VALVE					
SIZE	in	0.5	0.75	1	1.5
	mm	15	20	25	40
L		4.25	4.6	5	6.5
		108	117	127	165
H app		165	175	215	270
ØK app		95	95	105	150
Wt. kg app		3.0	4.5	6.0	10.0

DIMENSION TABLE #300 GLOBE VALVE					
SIZE	in	0.5	0.75	1	1.5
	mm	15	20	25	40
L		6.0	7.0	8.0	9.0
		152.5	178	203	228.5
H app		170	180	210	280
ØK app		95	95	105	150
Wt. kg app		4.0	6.0	8.0	17.0

DIMENSION TABLE #300 GATE VALVE					
SIZE	in	0.5	0.75	1	1.5
	mm	15	20	25	40
L		5.5	6.0	6.5	7.5
		140	152.5	165	190.5
H app		165	175	215	270
ØK app		95	95	105	150
Wt. kg app		4.0	5.0	7.5	13.5

DIMENSION TABLE #600 GLOBE VALVE					
SIZE	in	0.5	0.75	1	1.5
	mm	15	20	25	40
L		6.5	7.5	8.5	9.5
		165	190.5	216	241
H app		180	210	280	290
ØK app		95	105	150	150
Wt. kg app		4.5	6.5	8.5	17.5

DIMENSION TABLE #600 GATE VALVE					
SIZE	in	0.5	0.75	1	1.5
	mm	15	20	25	40
L		6.5	7.5	8.5	9.5
		165	190.5	216	241
H app		165	175	215	270
ØK app		95	95	105	150
Wt. kg app		4.5	5.5	8.5	17.5

PARTS	MATERIAL SPECIFICATION		
BODY	A105	F304	F316
BONNET	A105	F304	F316
WEDGE/PLUG	13%CR.	T304	T316
SEAT	13%CR.	T304	T316
SPINDLE	T410	T304	T316
GLAND BUSH	T410	T304	T316
GLAND FLANGE	A105	F304	
YOKE NUT	ASTM A 439 GR.D2/ AL-BRONZE		
HAND WHEEL	CAST STEEL		
HAND WHEEL NUT	GR.2H		
COLLAR BOLT/ STUD & NUT	B7/ 2H	B8/ 8 OR B7/ 2H	
EYE BOLT & NUT	B7/ 2H	B8/ 8	
GASKET	SPW S.S 304/316 WITH CAF/ GRAFOIL		
GLAND PACKING	GRAPHITE ASBESTOS INHIB. & INCONEL WIRE REIN.		
SCREW/RIVET&WASHER	STEEL		
WASHER	STEEL		
GRUB SCREW	STEEL		
NAME PLATE	ALUMINIUM/SS		

NO.	QTY.	PARTS	MATERIAL	REMARKS
01	01	BODY	ASTM A 216 GR. WCB	
04	02	PLATE	F6	
05	01	SEAT	F6	INTEGRAL
10	04	DISC BEARING	F6	HARDENED
17	01	SPACER BUSH	F6	
29	03MIN.	RETAINER PACKING	GRAPHITE	
6	02	SPRING BEARING	AISI 410	
37	02	BODY BEARING	AISI 410	
48	01	HINGE PIN	F6	
49	01	STOPPER PIN	AISI 410	
59	01	LIFTING HOOK	ASTM A 105	NOT SHOWN
70	02	HINGE PIN RETAINER	ASTM A 105	
70A	02	STOPPER PIN RETAINER	ASTM A 105	NOT SHOWN
79	02	SPRING	S.S. 316	

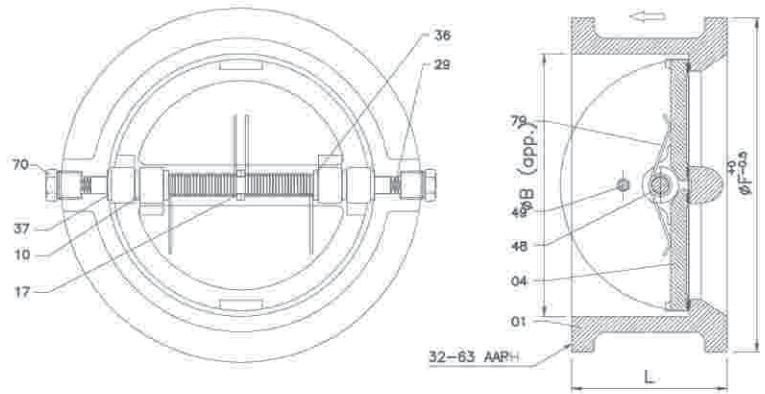

SIZE	in	3	4	6	8	10	12
	mm	80	100	150	200	250	300
L		73	73	98	127	146	181
ØF		136.5	174.5	222	279	340	409
ØB		87	113	165	206	270	300

SIZE	in	3	4	6	8	10	12
	mm	100	100	150	200	250	300
L		73	73	98	127	146	181
ØF		149	181	250.5	308	362	422
ØB		87	113	165	206	270	300

BUTTERFLY VALVE

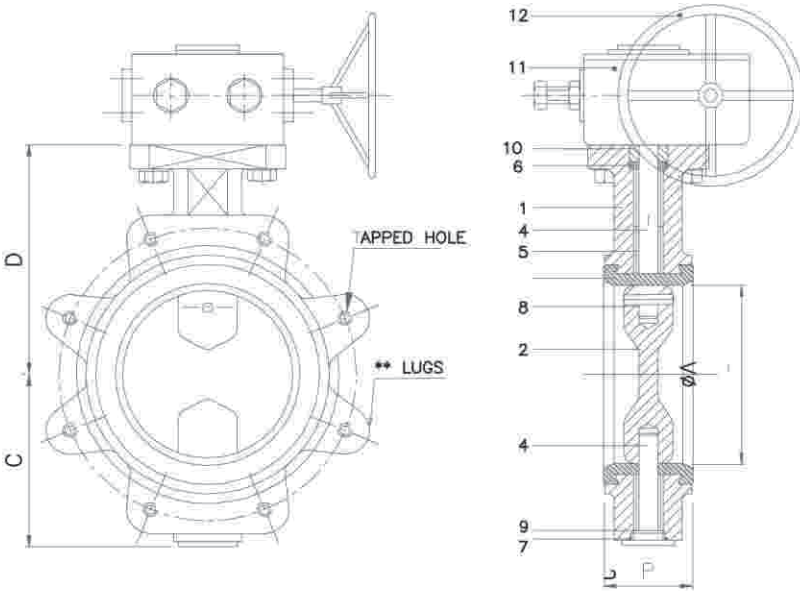

SIZE	in	8	10	12	14	16	18	20
	mm	200	250	300	350	400	450	500
ØA		200	250	300	336	586	436	486
B		60	68	78	78	154	114	127
C		163	203	228	265	435	330	355
D		198	245	270	312	490	390	410



NO.	QTY.	PARTS	MATERIAL
1	1	BODY	SGI GGG40+EPOXY
2	1	DISC	AL. BRONZE
3	1	BONDED SEAT	EPDM
4	2	SHAFT	AISI 316
5	2	BEARING	STEEL _ PTFE
6	1	O RING SHAFT	EPDM
7	1	O RING PLUG	EPDM
8	1	TAPER PIN	MONEL
9	1	PLUG/BOTTOM COVER	C-15/MS
10	1	TOP BUSHING	POLYACETAL
11	1	WORM GEAR	-
12	1	HANDWHEEL	MS

FLUSH BOTTOM VALVE

Class 150
OPEN INTO VALVE & OPEN INTO TANK



Flange ANSI B16.5



DIMENSION TABLE # 150				
SIZE	2"x2"	3"x3"	4"x4"	6"x6"
L	145	175	200	250
ØC	65	90	120	170
H	480	505	560	600
ØK	250	250	300	350
ØF	152	190	229	279
PCD	120.5	152.5	190.5	241.5
ØR	92	127	157	216
S	15.9	19.1	23.9	25.4
ØH	19	19	19	22
N	4	4	8	8
P	45	55	65	75
M	30	30	40	45

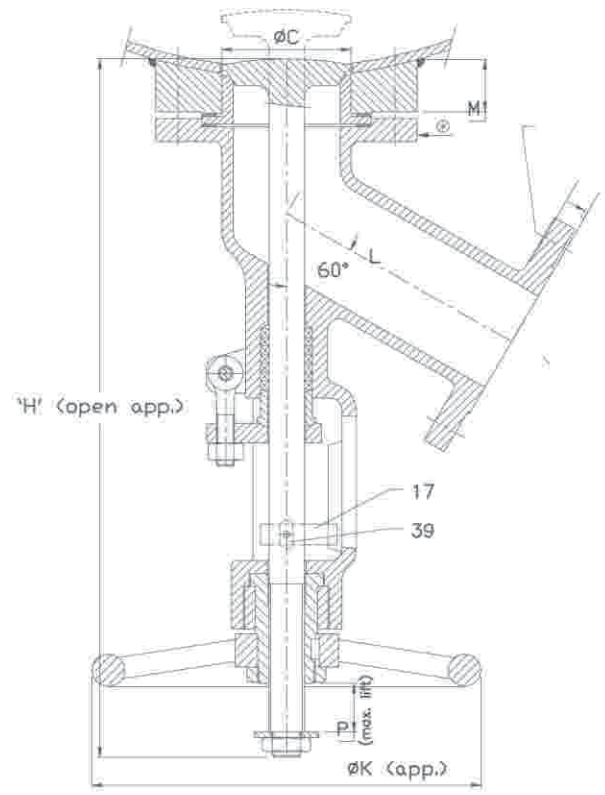

PARTS	MATERIAL SPECIFICATION
BODY	ASTM A 216 GR.WCB
PLUG	AISI 410 INTEGRAL
SEAT	13% CR. STEEL
SPINDLE	AISI 410
GLAND BUSH	AISI 410
GLAND FLANGE	ASTM A 515 GR.70
YOKE SLEEVE	ASTM A 439 GR.D2/AL.BRONZE
YOKE NUT	AISI 410
GUIDE PLATE	ASTM A 515 GR. 70
HAND WHEEL	CARBON STEEL
HAND WHEEL NUT	STEEL
EYE BOLT & NUT	A 193 GR.B7/A 194 GR.2H
CROSS BOLT & NUT	A 193 GR.B7/A 194 GR.2H
GASKET	SPW S.S. 304 WITH CAF
GLAND PACKING	GRAPH. ASB. WITH SACRIFICIAL INHIBITOR & INCONEL WIRE REINFORCEMENT
WASHER	STEEL
KEY	C40
LOCK NUT	STEEL
LOCKING BOLT	S.S.
NAME PLATE	S.S. 304

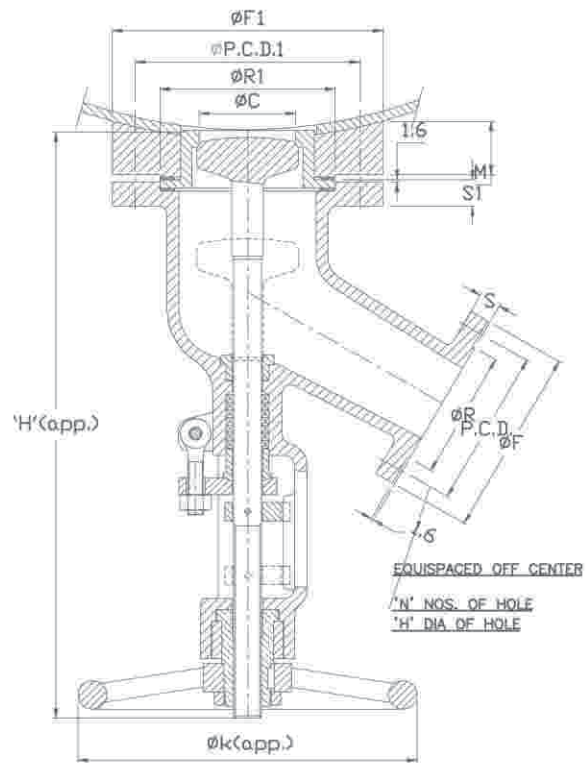

BASKET STRAINER



Length ANSI B16.10 - Flange ANSI B16.5

NO.	QTY.	PARTS	MATERIAL
1	1	BOTTOM PLATE	CARBON STEEL
2	1	SCREEN	S.S. AISI 316 (40MESH)
3	2	SEAMLESS PIPE	CARBON STEEL (ASTM A 53 GR B)
4	2	IN-OUT SIDE FLANGE	CARBON STEEL
5	1	SEAMLESS PIPE	CARBON STEEL (ASTM A 53 GR B)
6	1	SCREEN FRAME	CARBON STEEL
7	1	GUIDE RING	CARBON STEEL
8	1	SCREEN HANDLE	MILD STEEL
9	1	TOP FLANGE	CARBON STEEL
10	1	GASKET	COMPRESS ASBESTOS FIBRE
11	1	COVER	CARBON STEEL
12	AS REQD.	COVER BOLTS	CARBON STEEL

REFERED STANDARDS	HYDROSTATIC TEST PRESSURE	
	CLASS	BODY
ENDS FLANGE & DRILLED AS PER ANSI B16.5 CLASS 150 OR CLASS 300 R.F.	150#	30 KG/CM ²
	300#	76KG/CM ²

DIMENSION TABLE #150

SIZE	in	1	1.5	2	3	4	6	8	10	12	14	16	18	20	24
	mm	25	40	50	80	100	150	200	250	300	350	400	450	500	600
A		160	200	230	310	350	445	605	600	730	780	840	900	950	1120
D		108	127	152.4	190.5	229	279.5	343	406.5	483	533.5	597	635	698.5	813
I		11	14.3	16	19	24	25.4	28.6	30.5	32	35	36.5	40	43	47.5
E		51	73	92	127	157	216	270	324	381	413	470	534	584	692
K		79.4	98.4	120.7	152.4	190.5	241.3	298.5	362	431.8	476.3	539.8	577.9	535	749.3
N		4	4	4	4	8	8	8	12	12	12	16	16	20	20
M		16	16	19	19	19	22.2	22.2	25.4	25.4	28.6	28.6	32	32	35
X		125	156	165	210	250	318	350	380	400	420	460	520	580	680
L		250	300	350	450	550	700	750	1100	1150	1230	1390	1400	1500	1500

DIMENSION TABLE #300

SIZE	in	1	1.5	2	3	4	6	8	10	12	14	16	18	20	24
	mm	25	40	50	80	100	150	200	250	300	350	400	450	500	600
A		203	230	270	320	360	480	600	630	780	830	880	950	1000	1180
D		124	155.5	165	210	254	317.5	381	444.5	521	584.5	648	711.5	775	914.5
I		17.5	21	22.5	29	32	36.5	41.5	48	51	54	57.5	60.5	63.5	70
E		51	73	92	127	157	216	270	324	381	413	470	534	584	692
K		8.9	114.3	127	168.3	200	269.9	330.2	387.4	450.9	514.5	571.5	628.7	685.8	812.8
N		4	4	8	8	8	12	12	16	16	20	20	24	24	24
M		19	22.2	19	22.2	22.2	22.2	25.4	28.6	32	32	35	35	35	41.3
X		125	156	165	210	250	318	350	380	400	420	460	520	580	680
L		340	430	450	554	680	879	1000	1150	1210	1230	1390	1560	1720	2050

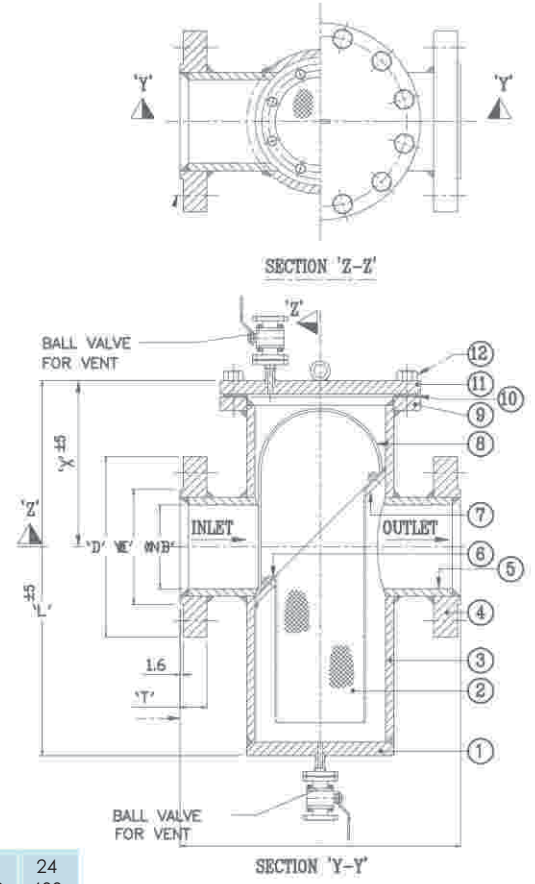

For Class 150 & 300

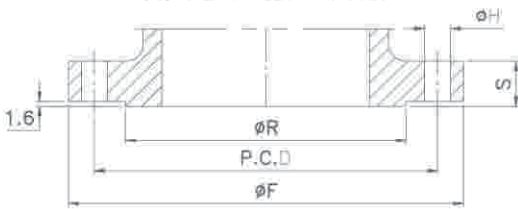

ANSI B 16.5



DIMENSION TABLE #150 STEEL FLANGE

NOMINAL SIZE		ØF		PCD		ØR		S		ØH		N
IN	MM	IN	MM	IN	MM	IN	MM	IN	MM	IN	MM	NO.
1/2	15	3.50	89	2.38	60.5	1.38	35	0.44	11.1	0.62	16	4
3/4	20	3.88	98	2.75	70.0	1.69	43	0.50(0.44)	12.7(11.1)	0.62	16	4
1	25	4.25	108	3.12	79.2	2.00	51	0.56(0.44)	14.3(11.1)	0.62	16	4
1 1/4	32	4.62	117	3.50	89.0	2.50	64	0.62(0.50)	15.9(12.7)	0.62	16	4
1 1/2	40	5.00	127	3.88	98.5	2.88	73	0.69(0.56)	17.5(14.3)	0.62	16	4
2	50	6.00	152	4.75	120.5	3.62	92	0.75(0.62)	19.1(15.9)	0.75	19	4
2 1/2	65	7.00	178	5.50	139.5	4.12	105	0.88(0.69)	22.3(17.5)	0.75	19	4
3	80	7.50	190	6.00	152.5	5.00	127	0.94(0.75)	23.9(19.1)	0.75	19	4
4	100	9.00	229	7.50	190.5	6.19	157	0.94	23.9	0.75	19	8
5	125	10.00	254	8.50	216.0	7.31	186	0.94	23.9	0.88	22	8
6	150	11.00	279	9.50	241.5	8.50	216	1.00	25.4	0.88	22	8
8	200	13.50	343	11.75	298.5	10.62	270	1.12	28.6	0.88	22	8
10	250	16.00	406	14.25	362.0	12.75	324	1.19	30.2	1.00	25	12
12	300	19.00	483	17.00	432.0	15.00	381	1.25	31.8	1.00	25	12
14	350	21.00	533	18.75	476.0	16.25	413	1.38	35.0	1.12	29	12
16	400	23.50	597	21.25	539.5	18.50	470	1.44	36.6	1.12	29	16
18	450	25.00	635	22.75	578.0	21.00	533	1.56	39.7	1.25	32	16
20	500	27.50	698	25.00	635.0	23.00	584	1.69	42.9	1.25	32	20
24	600	32.00	813	29.50	749.5	27.25	692	1.88	47.7	1.38	35	20

DIMENSION TABLE #300 STEEL FLANGE

NOMINAL SIZE		ØF		PCD		ØR		S		ØH		N
IN	MM	IN	MM	IN	MM	IN	MM	IN	MM	IN	MM	NO.
1/2	15	3.75	95	2.62	66.5	1.38	35	0.56	14.3	0.62	16	4
3/4	20	4.62	117	3.25	82.5	1.69	43	0.62	15.9	0.75	19	4
1	25	4.88	124	3.50	89.0	2.00	51	0.69	17.5	0.75	19	4
1 1/4	32	5.25	133	3.88	98.5	2.50	64	0.75	19.1	0.75	19	4
1 1/2	40	6.12	156	4.50	114.5	2.88	73	0.81	20.7	0.88	22	4
2	50	6.50	165	5.00	127.0	3.62	92	0.88	22.3	0.75	19	8
2 1/2	65	7.50	190	5.88	149.0	4.12	105	1.00	25.4	0.88	22	8
3	80	8.25	210	6.62	168.0	5.00	127	1.12	28.6	0.88	22	8
4	100	10.00	254	7.88	200.0	6.19	157	1.25	31.8	0.88	22	8
5	125	11.00	279	9.25	235.0	7.31	186	1.38	35.0	0.88	22	8
6	150	12.50	318	10.62	270.0	8.50	216	1.44	36.6	0.88	22	12
8	200	15.00	381	13.00	330.0	10.62	270	1.62	41.3	1.00	25	12
10	250	17.50	444	15.25	387.5	12.75	324	1.88	47.7	1.12	29	16
12	300	20.50	521	17.75	451.0	15.00	381	2.00	50.8	1.25	32	16
14	350	23.00	584	20.25	514.5	16.25	413	2.12	54.0	1.25	32	20
16	400	25.50	648	22.50	571.5	18.50	470	2.25	57.2	1.38	35	20
18	450	28.00	711	24.75	628.5	21.00	533	2.38	60.4	1.38	35	24
20	500	30.50	775	27.00	686.0	23.00	584	2.50	63.5	1.38	35	24
24	600	36.00	914	32.00	813.0	27.25	692	2.75	69.9	1.62	41	24

For Class 600 & 900

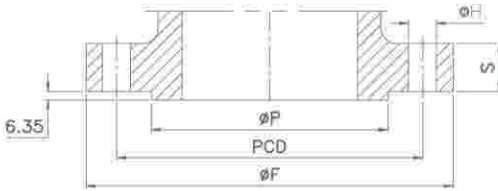

ANSI B 16.5



DIMENSION TABLE #600 STEEL FLANGE

NOMINAL SIZE		ØF		PCD		ØR		S		ØH		N
IN	MM	IN	MM	IN	MM	IN	MM	IN	MM	IN	MM	NO.
1/2	15	3.75	95	2.62	66.5	1.38	35	0.56	14.3	0.62	16	4
3/4	20	4.62	117	3.25	82.5	1.69	43	0.62	15.9	0.75	19	4
1	25	4.88	124	3.50	89.0	2.00	51	0.69	17.5	0.75	19	4
1 1/4	32	5.25	133	3.88	98.5	2.50	64	0.81	20.7	0.75	19	4
1 1/2	40	6.12	156	4.50	114.5	2.88	73	0.88	22.3	0.88	22	4
2	50	6.50	165	5.00	127.0	3.62	92	1.00	25.4	0.75	19	8
2 1/2	65	7.50	190	5.88	149.0	4.12	105	1.12	28.6	0.88	22	8
3	80	8.25	210	6.62	168.0	5.00	127	1.25	31.8	0.88	22	8
4	100	10.75	273	8.50	216.0	6.19	157	1.50	38.1	1.00	25	8
5	125	13.00	330	10.50	266.5	7.31	186	1.75	44.5	1.12	29	8
6	150	14.00	356	11.50	292.0	8.50	216	1.88	47.7	1.12	29	12
8	200	16.50	419	13.75	349.0	10.62	270	2.19	55.6	1.25	32	12
10	250	20.00	508	17.00	432.0	12.75	324	2.50	63.5	1.38	35	16
12	300	22.00	559	19.25	489.0	15.00	381	2.62	66.7	1.38	35	20
14	350	23.75	603	20.75	527.0	16.25	413	2.75	69.9	1.50	38	20
16	400	27.00	686	23.75	603.0	18.50	470	3.00	76.2	1.62	41	20
18	450	29.25	743	25.75	654.0	21.00	533	3.25	82.6	1.75	45	20
20	500	32.00	813	28.50	724.0	23.00	584	3.50	88.9	1.75	45	24
24	600	37.00	940	33.00	838.0	27.25	692	4.00	101.6	2.00	51	24

DIMENSION TABLE #900 STEEL FLANGE

NOMINAL SIZE		ØF		PCD		ØR		S		ØH		N
IN	MM	IN	MM	IN	MM	IN	MM	IN	MM	IN	MM	NO.
2	50	8.50	216	6.50	165.0	3.62	92	1.50	38.1	1.00	25	8
2 1/2	65	9.62	244	7.50	190.5	4.12	105	1.62	41.2	1.12	29	8
3	80	9.50	241	7.50	190.5	5.00	127	1.50	38.1	1.00	25	8
4	100	11.50	292	9.25	235.0	6.19	157	1.75	44.5	1.25	32	8
5	125	13.75	349	11.00	279.5	7.31	186	2.00	50.8	1.38	35	8
6	150	15.00	381	12.50	317.5	8.50	216	2.19	55.6	1.25	32	12
8	200	18.50	470	15.50	393.7	10.62	270	2.50	63.5	1.50	38	12
10	250	21.50	546	18.50	470.0	12.75	324	2.75	69.9	1.50	38	16
12	300	24.00	610	21.00	533.5	15.00	381	3.12	79.2	1.50	38	20
14	350	25.25	641	22.00	559.0	16.25	413	3.38	85.9	1.62	41	20
16	400	27.75	705	24.25	616.0	18.50	470	3.50	88.9	1.75	45	20
18	450	31.00	787	27.00	686.0	21.00	533	4.00	101.6	2.00	51	20
20	500	33.75	857	29.50	749.5	23.00	584	4.25	108.0	2.12	54	20
24	600	41.00	1041	35.50	901.5	27.25	692	5.50	139.7	2.62	67	20

ASTM CAST	ASTM FORGED	MATERIAL DESIGNATION	WORKING TEMPERATURE* °F/°C ASME B16.34
A216WCB	A105	CARBON STEEL	800 / 975 MAXIMUM
A217WC1	A182F1	C-0.5 MO	875
A217WC6	A182F11	2.25 CR-0.5 MO	1100 / 593 MAXIMUM
A217WC9	A182F22	2.25 CR-1 MO	1100 / 593 MAXIMUM
A217C5	A182F5	5 CR-0.5 MO	1200 / 649 MAXIMUM
A217C12	A182F9	9 CR-1 MO	1200 / 649 MAXIMUM
A352LCB	A350LF2	CARBON STEEL	-50 / -46 MINIMUM
A352LCC	-	CARBON STEEL	-50 / -46 MINIMUM
A352LC1	-	C-0.5 MO	-75 / -59 MINIMUM
A352LC2	-	2.5 NI	-100 / -73 MINIMUM
A352LC3	-	3.5 NI	-150 / -101 MINIMUM
A351CF8M	A182F316	13 CR. 9 NI	1500 / 816 MAXIMUM
A351CF8	A182F304	18 CR. 8 NI	1500 / 816 MAXIMUM
A351CF3M	A182F316L	16CR-12NI-2MO	850 / 454 MAXIMUM
A351CF3	A182F304L	18 CR. 8 NI	800 / 427 MAXIMUM
A351CN7M	-	29NI-20.5CR-3.5CU-2.5MO	300 / 149 MAXIMUM

TRIM MATERIAL

API 600 TRIM NUMBER	SYMBOL	MATERIAL DESIGNATION	SEAT SURFACE	STEM MATERIAL
1	1	13% CR.	13% CR.	ASTM A 276 - T410
2	2	18% CR. 8% NI	18% CR. 8% NI	ASTM A 276 - T304
5	5	STELLITE	STELLITE	ASTM A 276 - T410
8	8	13% CR.	STELLITE	ASTM A 276 - T410
9	9	MONEL	MONEL	NI CU ALLOY MONEL
10	10	18% CR. 8% NI	18% CR. 8% NI	ASTM A 276 - T316
12	12	18% CR. 8% NI	STELLITE	ASTM A 276 - T316
13	13	ALLOY 20 19% CR. 29% NI	ALLOY 20 19% CR. 29% NI	ASTM B473
16	16	STELLITE	STELLITE	ASTM A 276 - T316

PRESSURE TEMPERATURE RATINGS



ASME B 16.34

SERVICE TEMP.		CLASS 150					CLASS 300					CLASS 600				
°F	°C	WCB (A)	WC1 (B)(C.)	WC6 (C.)	WC9 (C.)	C5 (C.)	WCB (A)	WC1 (B)(C.)	WC6 (C.)	WC9 (C.)	C5 (C.)	WCB (A)	WC1 (B)(C.)	WC6 (C.)	WC9 (C.)	C5 (C.)
-20 TO	-29 TO	285	265	290	290	290	740	695	750	750	750	1480	1390	1500	1500	1500
100	38	260	260	260	260	260	675	680	750	750	745	1350	1360	1500	1500	1490
200	93	230	230	230	230	230	655	655	720	730	715	1315	1305	1445	1455	1430
300	149	200	200	200	200	200	635	640	695	705	705	1270	1280	1385	1410	1410
400	204	170	170	170	170	170	600	620	665	665	665	1200	1245	1330	1330	1330
500	260	140	140	140	140	140	550	605	605	605	605	1095	1210	1210	1210	1210
600	316	125	125	125	125	125	535	590	590	590	590	1075	1175	1175	1175	1175
650	343	110	110	110	110	110	535	570	570	570	570	1065	1135	1135	1135	1135
700	371	95	95	95	95	95	505	530	530	530	530	1010	1065	1065	1065	1055
750	399	80	80	80	80	80	410	510	510	510	510	825	1015	1015	1015	1015
800	427	65	65	65	65	65	270	485	485	485	485	535	975	975	975	965
850	454	50	50	50	50	50	170	450	450	450	370	345	900	900	900	740
900	482	35	35	35	35	35	105	280	320	375	275	205	560	640	755	550
950	510	20	20	20	20	20	50	165	215	260	200	105	330	430	520	400
1000	538			20*	20*	20*			145	175	145			290	350	290
1050	566			20*	20*	20*			95	110	100			190	220	200
1100	593					20*					60					125
1150	621					15*					35					70
1200	649															
HYDROSTATIC SHELL		450	425				1125	1075		1150		2250	2100		2275	
TEST PRESSURE		31.5	29				79	75		805		157.5	147		154	
VALVE CLOSURE		FLUID	315	300			825	770		830		1630	1535		1655	
TEST PRESSURE		AIR	22.00	21.00			58	54		58		114	107		116	
			100/7				100/7				100/7					

SERVICE TEMP.		CLASS 900					CLASS 1500					CLASS 2500				
°F	°C	WCB (A)	WC1 (B)(C.)	WC6 (C.)	WC9 (C.)	C5 (C.)	WCB (A)	WC1 (B)(C.)	WC6 (C.)	WC9 (C.)	C5 (C.)	WCB (A)	WC1 (B)(C.)	WC6 (C.)	WC9 (C.)	C5 (C.)
-20 TO	-29 TO	2220	2085	2250	2250	2250	3705	3470	3750	3750	3750	6170	5785	6250	6250	6250
100	38	2025	2035	2250	2250	2235	3375	3395	3750	3750	3725	5625	5660	6250	6250	6205
200	93	1970	1955	2165	2185	2150	3280	3260	3610	3640	3580	5470	5435	6015	6070	5965
300	149	1900	1920	2080	2115	2115	3170	3200	3465	3530	3530	5280	5330	5775	5880	5880
400	204	1795	1865	1995	1995	1995	2995	3105	3425	3325	3325	4990	5180	5540	5540	5540
500	260	1640	1815	1815	1815	1815	2735	3025	3025	3025	3025	4560	5040	5040	5040	5040
600	316	1610	1765	1765	1765	1765	2685	2940	2940	2940	2940	4475	4905	4905	4905	4905
650	343	1600	1705	1705	1705	1705	2665	2840	2840	2840	2840	4440	4730	4730	4730	4730
700	371	1510	1595	1595	1595	1585	2520	2660	2660	2660	2640	4200	4430	4430	4430	4400
750	399	1235	1525	1525	1525	1525	2060	2540	2540	2540	2540	3430	4230	4230	4230	4230
800	427	805	1460	1460	1460	1450	1340	2435	2435	2435	2415	2230	4060	4060	4060	4030
850	454	515	1350	1350	1350	1110	860	2245	2245	2245	1850	1430	3745	3745	3745	3085
900	482	310	845	955	1130	825	515	1405	1595	1885	1370	860	2345	2655	3145	2285
950	510	155	495	650	780	595	260	825	1080	1305	995	430	1370	1800	2170	1655
1000	538			430	525	430			720	875	720			1200	1455	1200
1050	566			290	330	300			480	550	495			800	915	830
1100	593				205	185					310					515
1150	621				125	105					170					285
1200	649															
HYDROSTATIC SHELL		3350	3150		3375		5575	5525	5650			9275	8700		9375	
TEST PRESSURE		235	220.5		236.5		390	387	390			650	609		656	
VALVE CLOSURE		FLUID	2445	2295		2475	4080	3817	4130			6780	6365		6875	
TEST PRESSURE		AIR	171	160.5		173	286	267	280			475	445		481	
			100/7				100/7				100/7					

PRESSURE TEMPERATURE RATINGS



SERVICE TEMP.		CLASS 150				CLASS 300				CLASS 600			
°C	°F	CF8		CF8M		CF8		CF8M		CF8		CF8M	
-29 TO	-20 TO	PSIG	KGF/CM2	PSIG	KGF/CM2	PSIG	KGF/CM2	PSIG	KGF/CM2	PSIG	KGF/CM2	PSIG	KGF/CM2
38	100	275	19.2	275	19.2	720	50.4	720	50.4	1440	100.8	1440	100.8
93	200	230	16.1	235	16.45	600	42	620	43.4	1200	84	1240	86.8
149	300	205	14.3	215	15.05	540	37.8	560	39.2	1080	75.6	1120	78.4
204	400	190	13.3	195	13.65	495	34.7	515	36.05	995	69.65	1025	71.75
260	500	170	12	170	11.9	465	32.55	480	33.6	930	65.1	955	66.85
316	600	140	9.8	140	9.8	435	30.45	450	31.5	875	61.25	900	63
343	650	125	8.75	125	8.75	430	30.1	445	31.15	860	60.2	890	62.3
371	700	110	7.7	110	7.7	425	29.75	430	30.1	850	59.5	870	60.9
399	750	95	6.65	95	6.65	415	29.05	425	29.75	830	58.1	855	59.85
427	800	80	5.6	80	5.6	405	28.35	420	29.4	805	56.35	845	59.15
454	850	65	4.55	65	4.55	395	27.65	420	29.4	790	55.3	835	58.45
482	900	50	3.5	50	3.5	390	27.3	415	29.05	780	54.6	830	58.1
510	950	35	2.45	35	2.45	380	26.6	385	26.95	765	53.55	775	54.25
538	1000	20	1.4	20	1.4	320	22.4	350	24.5	640	44.8	700	49.0
566	1050	20*	1.4	20*	1.4	310	21.7	345	24.15	615	43.05	685	47.95
593	1100	20*	1.4	20*	1.4	255	17.85	305	21.35	515	36.05	610	42.7
621	1150	20*	1.4	20*	1.4	200	14	235	16.45	400	28	475	33.25
649	1200	20*	1.4	20*	1.4	155	10.85	185	12.95	310	21.7	370	25.9
677	1250	20*	1.4	20*	1.4	115	8.05	145	10.15	225	15.75	295	20.65
704	1300	20*	1.4	20*	1.4	85	6.0	115	8.05	170	11.9	235	16.45
732	1350	20*	1.4	20*	1.4	60	4.2	95	6.65	125	8.75	190	13.3
760	1400	20*	1.4	20*	1.4	50	3.5	75	5.25	95	6.65	150	10.5
788	1450	15*	1.4	20*	1.4	35	2.5	60	4.2	70	4.9	115	8.05
816	1500	10*	0.7	15*	0.7	25	1.75	40	2.8	55	3.85	85	5.95
HYDROSTATIC SHELL TEST PRESSURE		425/30				1100 / 78				2175 / 153			
VALVE CLOSURE TEST PRESSURE	HYDROSTATIC	305/22				795 / 56				1585 / 115			
	AIR	100/7				100 / 7				100 / 7			

SERVICE TEMP.		CLASS 900				CLASS 1500			
°C	°F	CF8		CF8M		CF8		CF8M	
-29 TO	-20 TO	PSIG	KGF/CM2	PSIG	KGF/CM2	PSIG	KGF/CM2	PSIG	KGF/CM2
38	100	2160	151.2	2160	151.2	3600	252	3600	252
93	200	1800	126	1860	130.2	3000	210	3095	216.65
149	300	1620	113.4	1680	117.6	2700	189	2795	195.65
204	400	1490	104.3	1540	107.8	2485	174.0	2570	179.9
260	500	1395	97.5	1435	100.4	2330	163.1	2390	167.3
316	600	1310	91.7	1355	94.85	2185	152.95	2255	157.85
343	650	1290	90.3	1330	93.1	2150	150.5	2220	155.4
371	700	1275	89.25	1305	91.4	2125	148.75	2170	151.9
399	750	1245	87.2	1280	89.6	2075	145.25	2135	149.45
427	800	1210	84.7	1265	88.55	2015	141.05	2110	147.7
454	850	1190	83.3	1255	87.85	1980	138.6	2090	146.3
482	900	1165	81.55	1245	87.2	1945	136.15	2075	145.25
510	950	1145	80.15	1160	81.2	1910	133.7	1930	135.1
538	1000	965	67.55	1050	73.5	1605	112.35	1750	122.5
566	1050	925	64.8	1030	72.1	1545	108.15	1720	120.4
593	1100	770	53.9	915	64.05	1285	89.95	1525	106.75
621	1150	595	41.65	710	49.7	995	69.65	1185	82.95
649	1200	465	32.55	555	38.85	770	53.9	925	64.75
677	1250	340	23.8	440	30.8	565	39.55	735	51.5
704	1300	255	17.85	350	24.5	430	30.1	585	40.95
732	1350	185	13.0	290	20.3	310	21.7	480	33.6
760	1400	145	10.15	225	15.75	240	16.8		26.6
788	1450	105	7.35	175	12.25	170	11.9		20.3
816	1500	80	5.6	125	8.75	135	9.45		14.35
HYDROSTATIC SHELL TEST PRESSURE		3250 / 230				5400 / 380			
VALVE CLOSURE TEST PRESSURE	HYDROSTATIC	2380 / 170				3960 / 280			
	AIR	100/7				100 / 7			

ASTM CODE	CHEMICAL COMPOSITIONS %										MECHANICAL			
	C	MN	P	S	SI	CR	MO	NI	CU	V	TENSILE MPA	YIELD MPA	% ELONG ATION	% REDUCT. AREA
	MAX.	MAX.	MAX.	MAX.	MAX.	MAX.	MAX.	MAX.	MAX.	MAX.	MIN.	MIN.	MIN.	MIN.
A216 WCB	0.30	1.00	0.040	0.045	0.60	0.50	0.20	0.50	0.30	0.03	485	250	22	35
A216 WCC	0.25	1.20	0.040	0.045	0.60	0.50	0.20	0.50	0.30	0.03	485	275	22	35
A217 WC1	0.25	0.80	0.040	0.045	0.60		0.65		0.50		450	240	24	35
A217 WC5	0.05 0.20	0.40 0.70	0.040	0.045	0.60	0.50 0.90	0.90 1.20	0.60 1.00	0.50	0.10 TU	485TO 655	275	20	35
A217 WC6	0.20	0.80	0.040	0.045	0.60	1.50	0.65		0.50		485	275	20	35
A217 WC9	0.18	0.70	0.040	0.045	0.60	2.75	1.20		0.50		485	275	20	35
A217 C5	0.20	0.70	0.040	0.045	0.75	6.50	0.65		0.50		620	415	18	35
A217 CA15	0.15	1.00	0.040	0.040	1.50	14.00	0.50	1.00			620	450	18	30
A351 CF8	0.08	1.50	0.040	0.040	2.00	21.00	0.50	11.00			485	205	35	
A351 CF8M	0.08	1.50	0.040	0.040	1.50	21.00	3.00	12.00			485	205	30	
A351 CF3	0.03	1.50	0.040	0.040	2.00	21.00	0.50	12.00			485	205	35	
A351 CF3M	0.03	1.50	0.040	0.040	1.50	21.00	3.00	13.00			485	205	30	
A351 CN7M	0.07	1.50	0.040	0.040	1.50	22.00	3.00	30.50	4.00		425	170	35	
A352 LCB	0.30	1.00	0.040	0.045	0.60	0.50	0.20	0.50	0.30	0.03	450	240	24	35
A352 LCC	0.25	1.20	0.040	0.045	0.60	0.50	0.20	0.50	0.30	0.03	485	275	22	35
A105	0.35	1.05	0.035	0.040	0.35	0.30	0.12	0.40	0.40	0.05	485	250	30	30
A182 F304	0.08	2.00	0.040	0.030	1.00	20.00		11.00			515	205	30	50
A182 F316	0.08	2.00	0.040	0.030	1.00	18.00	3.00	14.00			515	205	30	50
A182 F304L	0.04	2.00	0.040	0.030	1.00	20.00	0.44 0.65	13.00			485	170	30	50
A182 F316L	0.04	2.00	0.040	0.030	1.00	18.00	3.00	15.00			485	170	30	50
A182 F5	0.15	0.30 0.60	0.030	0.030	0.50	1.00 1.50	0.44 0.65	0.50			485	275	20	35
A182 F11 CL1	0.05 0.15	0.30 0.60	0.030	0.030	0.50 1.00	4.00 6.00	0.87 1.13				415	205	20	45
A182 F11 CL2	0.10	0.30	0.040	0.040	0.50	1.00	0.44				485	276	20	30
A182 F11 CL3	0.20	0.80	0.040	0.040	1.00	1.50	0.65				515	310	20	30
A182 F22 CL1	0.05 0.15	0.30 0.61	0.040	0.040	0.50	2.00 2.50	0.87 1.14			0.02 0.03	415	205	20	35
A182 F22 CL2	0.05 0.16	0.30 0.61	0.040	0.040	0.50	2.00 2.51					515	310	20	30
A350 LF2	0.03	0.60 1.35	0.035	0.040	0.15 0.30	0.30	0.12	0.40	0.40		485TO 655	250	30	197
A276 410	0.15	1.00	0.040	0.030	1.00	11.5 13.5						550	15	45
A276 420	0.15	1.00	0.040	0.030	1.00	14.00					690			
A193 B7	0.49	1.10	0.035	0.040	0.35	1.20	0.25				860	720	16	50
A193 B7M	0.49	1.10	0.035	0.040	0.35	1.20	0.25				690	550	18	50
A193 B8	0.08	2.00	0.045	0.030	1.00	20.00		10.50			515	205	30	50
A193 B8M	0.08	2.00	0.045	0.030	1.00	18.00	3.00	14.00			515	205	30	50
A194 2H	0.40	1.00	0.040	0.050	0.40									
A194 2HM	0.40	1.00	0.040	0.050	0.40									
A320 L7	0.48	1.00	0.035	0.040	0.35	1.10	0.25				860	725	16	50
A320 L7M	0.48	1.00	0.035	0.040	0.35	1.10	0.25				690	550	18	50
A194 8	0.08	2.00	0.045	0.030	1.00	20.00		10.50						

NO.	AMERICAN STD.	BRITISH STD.
SHELL WALL THICKNESS AND GENERAL VALVE DESIGN SPECIFICATIONS, CAST STEEL, FORGED STEEL.	API 600 / API 6D/API 602	BS 1414 (GATE VALVE)
		BS 1873 (GLOBE VALVE)
		BS 1868 (CHECK VALVE)
		BS 5352
PRESSURE-TEMPERATURE RATING	ASME B16.34/ API 602/ API 6D	BS1560 / BS 5352
FACE-TO-FACE DIMENSIONS FLANGED END	ANSI B16.10/ API 6D	BS 2080
END-TO-END DIMENSIONS BUTT WELD END		
END FLANGE DIMENSIONS	ANSI B16.5*	BS 3293/ BS1560
GASKET CONTACT FACING		
WELDING END DIMENSIONS BUTT WELD	ANSI B16.25	BS1414 (GATE VALVE)
		BS1873 (GLOBE VALVE)
		BS1868 (CHECK VALVE)
WELDING END DIMENSIONS SOCKET WELD	ANSI B16.11	
RADIOGRAPH & NDT REQUIREMENTS	ASME B16.34	BS 6755
INSPECTION AND TESTING STANDARD	API 598	

VALVES MATERIAL

API 600 and BS 1414 / 1873 / 1868 specify the following valve components parts as the valve trim

DESCRIPTION	GATE VALVE	GLOBE VALVE	CHECK VALVE
Wedge/Disc seat surface	-	-	-
Body seat surface	-	-	-
Bonnet bush (Backseat)	-	-	-
Stem	-	-	-
Others	Internal small parts	Plug nut	Hinge pin



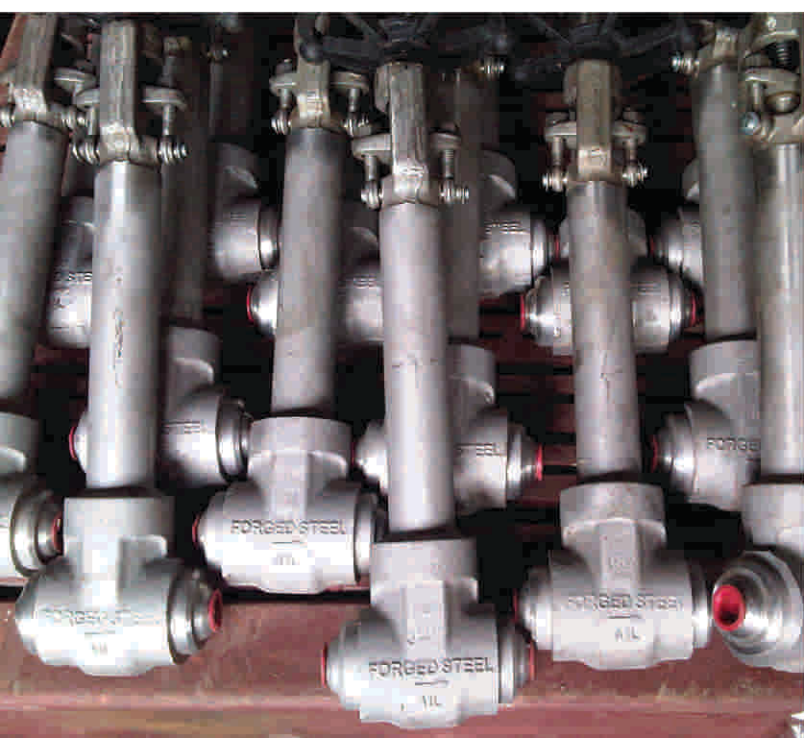
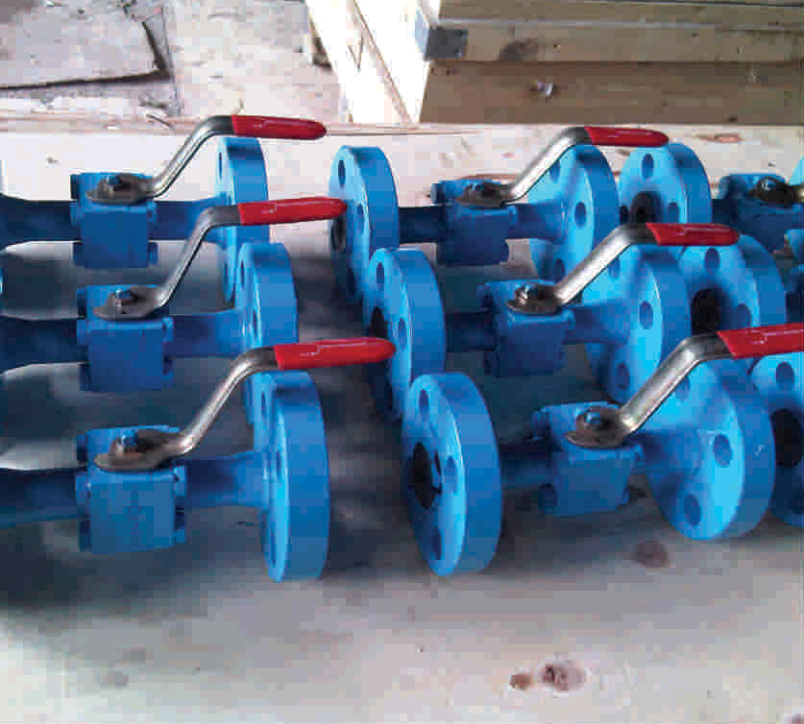



SANCO VALVES
Pvt. Ltd.

OFFICE ADDRESS :
SANCO VALVES PVT. LTD.

Office No. 6, Ideal Market, Near Central Bank,
Kausa, Dist. Thane - 400612 - INDIA
Email : info@sancovalves.com

designed by **LEMONZSTUDIO** | 9222182992